

Construction

Close-coupled self-priming liquid ring pumps with star impeller.

CA: version with pump casing and lantern bracket in cast iron.
B-CA: version with pump casing and lantern bracket in bronze (the pumps are supplied fully painted).

Applications

For clean liquids without abrasives, without suspended solids, non-explosive, non-aggressive for the pump materials.
If the liquid to be pumped has entrained air or gas or the flow in the suction pipe is not stable.
For drawing water out of a well.
For increasing network pressure (follow local specifications).

Operating conditions

Liquid temperature from -10 °C to +90 °C.
Ambient temperature up to 40 °C.
Negative suction pressure up to 9 m.
Continuous duty.

Motor

2-pole induction motor, 50 Hz (n = 2900 rpm).

CA: three-phase 230/400 V ± 10%.

CAM: single-phase 230 V ± 10%, with thermal protector.
Capacitor inside the terminal box.

Insulation class F.

Protection IP 54.

Classification scheme IE2 for three-phase motors from 0,75 kW.

Constructed in accordance with: EN 60034-1; EN 60034-30.
EN 60335-1, EN 60335-2-41.

Materials

Components	CA	B-CA
Pump casing	Cast iron	Bronze
Lantern bracket	GJL 200 EN 1561	G-Cu Sn 10 EN 1982
Impeller	Brass P- Cu Zn Pb 2 UNI 5705	
Shaft	Chrome steel 1.4104 EN 10088 AISI 430	Cr-Ni-Mo steel 1.4401 EN 10088 AISI 316
Mechanical seal	Carbon - Ceramic - NBR	

Special features on request

- Other voltages.
- Frequency 60 Hz (as per 60 Hz data sheet).
- Protection IP 55.
- Special mechanical seal
- Higher or lower liquid or ambient temperatures.

Coverage chart n ≈ 2900 rpm

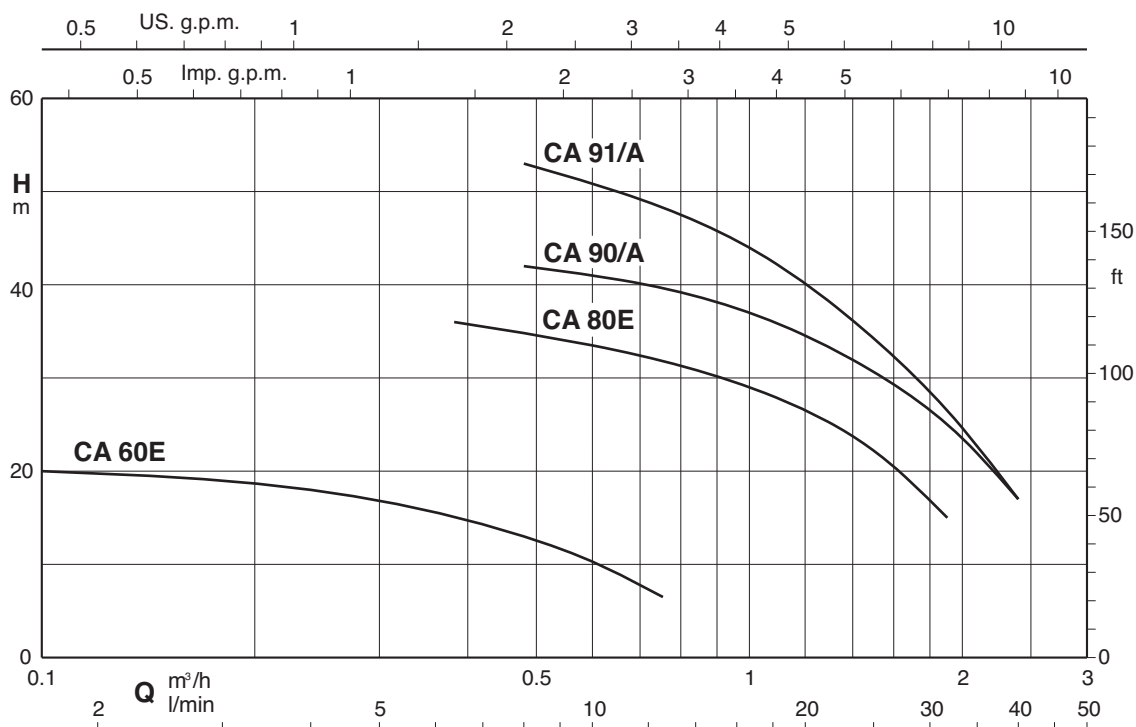

Performance $n \approx 2900$ rpm

3 ~	230 V 400 V		1 ~	230 V		P ₁	P ₂	Q m ³ /h l/min	H											
	A	A		A	kW	kW	HP		0,12	0,24	0,38	0,48	0,6	0,75	1	1,2	1,5	1,89	2,4	
CA 60E B-CA 60E	1,7	1	CAM 60E B-CAM 60E	1,6	0,26	0,15	0,2	H m	20	18	15,5	13	10,5	6,5						
CA 80E B-CA 80/A	2,8 2,3	1,6 1,3	CAM 80E B-CAM 80/A	3,3 3,6	0,72	0,45	0,6				36	35	33,5	31,5	29	26	22	15		
CA 90/A B-CA 90/A	3	1,7	CAM 90/A B-CAM 90/A	4,5	0,9	0,55	0,75					42	41	40	37	34	30	25	17	
CA 91/A B-CA 91/A	3,7	2,2	CAM 91/A B-CAM 91/A	5,7	1,2	0,75	1					53	51	48	44	39	34	26,5	17	

P₁ Maximum power input.

P₂ Rated motor power output.

B-CA = Bronze construction.

H Total head in m.

Dimensions and weights

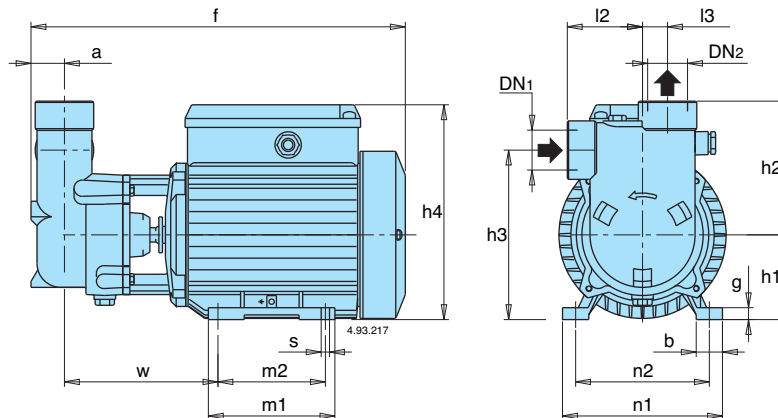

TYPE	DN ₁	DN ₂	mm															kg		
			ISO 228		a	f	h ₁	h ₂	h ₃	h ₄	m ₁	m ₂	n ₁	n ₂	b	s	l ₂	l ₃	w	g
CA 60E - B-CA 60E	G 1/2	G 1/2	18	256	63	65	103	158	96	80	122	100	22	7	45	14	103	8	6	6,8
CA 80E	G 3/4	G 3/4	23	272	63	90	126	158	96	80	122	100	22	7	55	17	109	8	7,6	-
CA 90/A	G 1	G 1	28	318	71	112	142	182	106	90	134	112	22	7	63	21	128	10	10,8	-
CA 91/A																			11,4	-

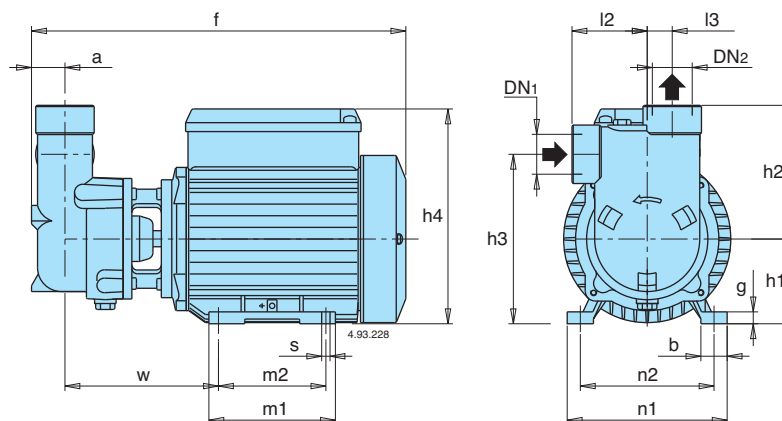

TYPE	DN ₁	DN ₂	mm															kg		
			ISO 228		a	f	h ₁	h ₂	h ₃	h ₄	m ₁	m ₂	n ₁	n ₂	b	s	l ₂	l ₃	w	g
B-CA 80/A	G 3/4	G 3/4	23	307	71	90	134	182	106	90	134	112	22	7	55	17	122	10	10	
B-CA 90/A	G 1	G 1	28	318	71	112	142	182	106	90	134	112	22	7	63	21	128	10	13,1	
B-CA 91/A																			13,9	

Characteristic curves $n \approx 2900$ rpm

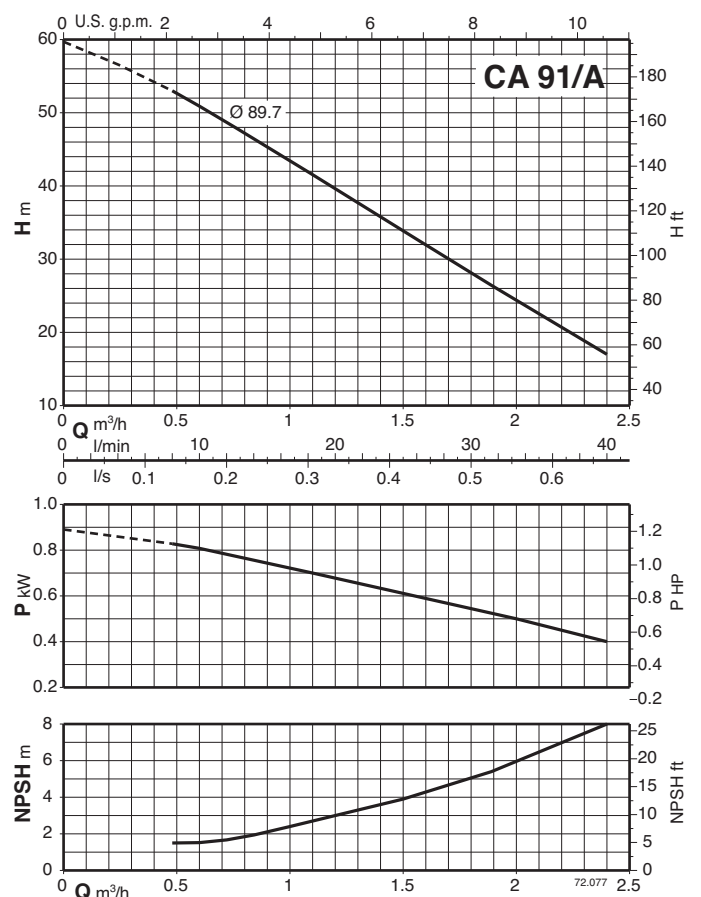
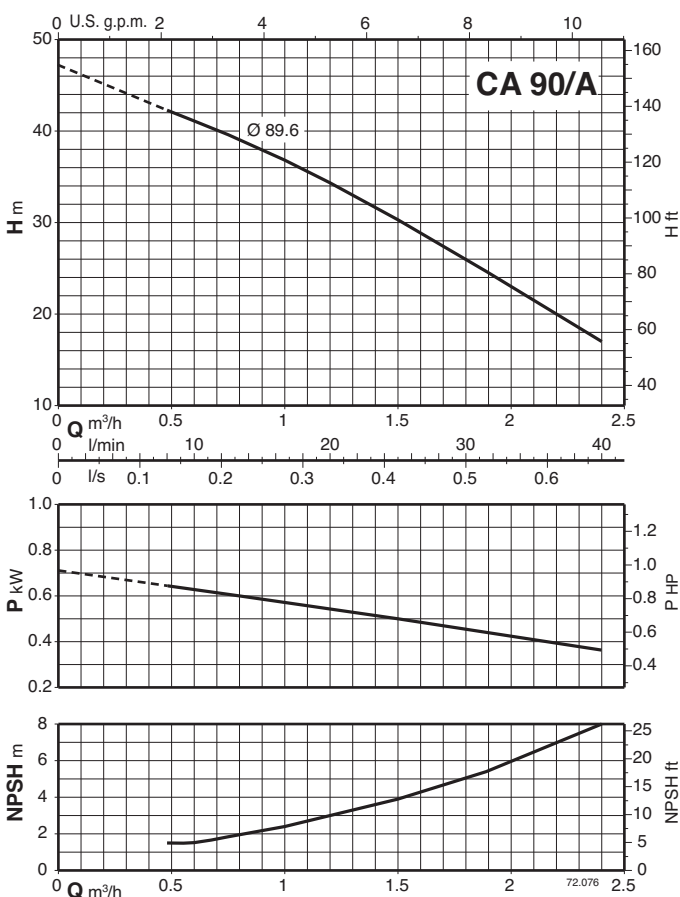
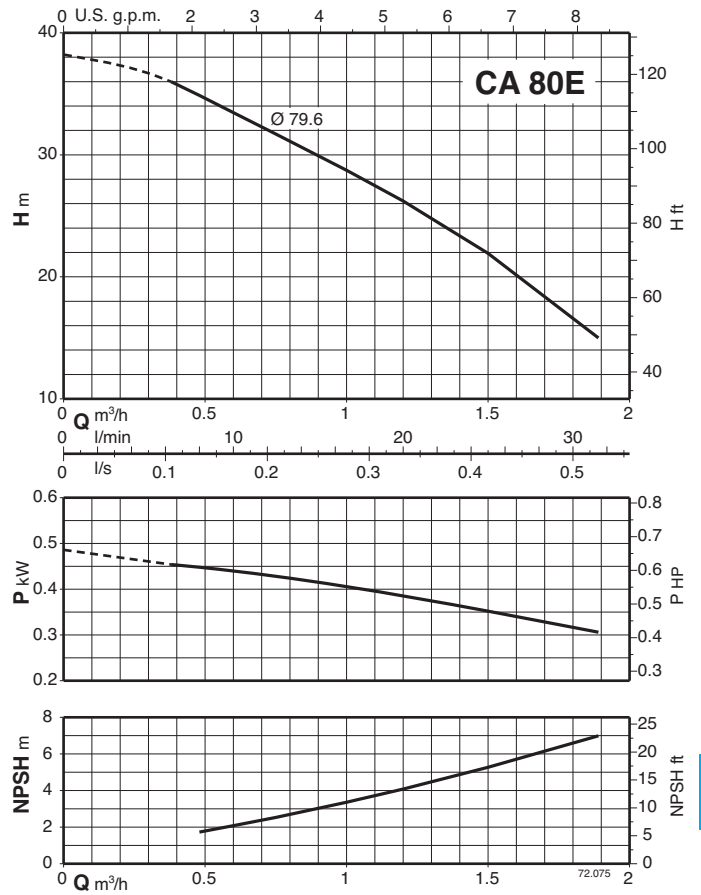
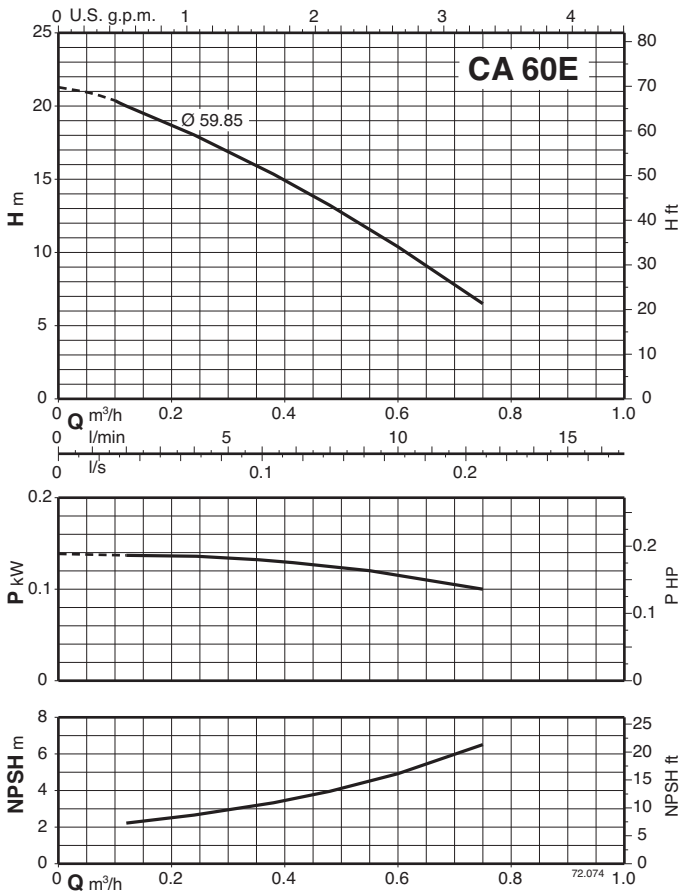

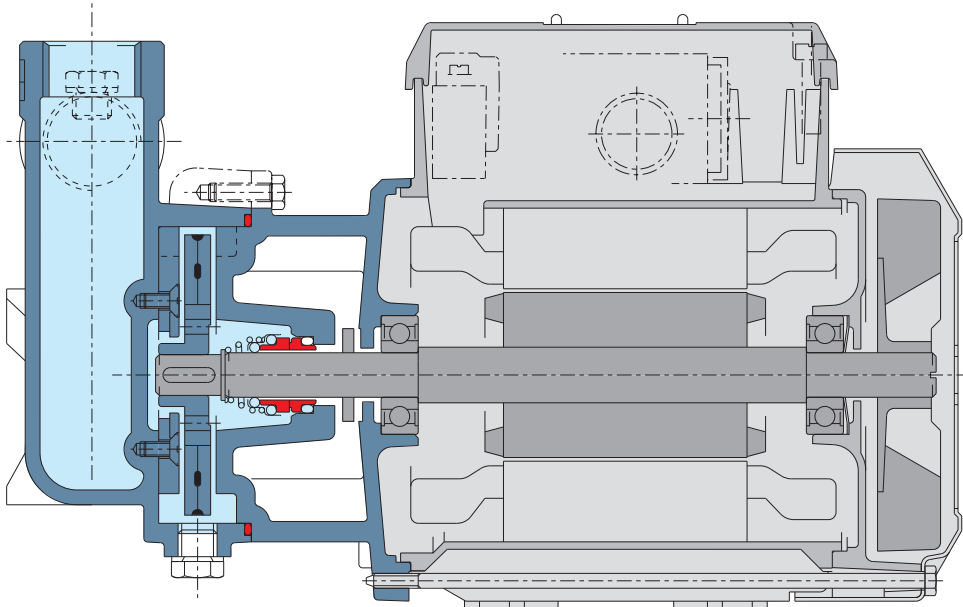
Features**FAST SELF PRIMING**

The hydraulic design ensures fast self priming once the pump body is filled with water.

FLEXIBILITY

The option to choose between cast iron and bronze materials for the hydraulic parts in contact with the pumped liquid allows CA series pumps to be selected for use with different types of liquids.

EASY MAINTENANCE

The construction features an anti-wear ring screwed to the pump body, allowing for rapid replacement in case of wear.