



Construction

Close-coupled centrifugal pumps with open impeller.
Free-flow impeller (vortex or recessed impeller) for type C 16/1E.

C: version with pump casing and lantern bracket in cast iron.
B-C: version with pump casing and lantern bracket in bronze (the pumps are supplied fully painted).

Applications

For moderately dirty liquids or emulsions.
For industry and agriculture.

Operating conditions

Liquid temperature from -10 °C to +90 °C.
Ambient temperature up to 40 °C.
Total suction lift up to 8 m.
Maximum permissible working pressure: 6 bar.
Maximum size of solids: 4 mm.
Continuous duty.

Motor

2-pole induction motor, 50 Hz (n = 2900 rpm).

C: three-phase 230/400 V ± 10%.

CM: single-phase 230 V ± 10%, with thermal protector.
Capacitor inside the terminal box.

Insulation class F.

Protection IP 54.

Classification scheme IE2 for three-phase motors from 0,75 kW.

Constructed in accordance with: EN 60034-1; EN 60034-30.
EN 60335-1, EN 60335-2-41.

Materials

Component	C	B-C
Pump casing	Cast iron GJL 200 EN 1561	Bronze G-Cu Sn 10 EN 1982
Lantern bracket	Cast iron GJL 200 EN 1561	Bronze G-Cu Sn 10 EN 1982
Impeller	Brass P- Cu Zn 40 Pb 2 UNI 5705	
Shaft	Chrome steel 1.4104 EN 10088 (AISI 430)	Cr-Ni-Mo steel 1.4401 EN 10088 (AISI 316)
	Chrome-nickel steel 1.4305 EN 10088 (AISI 303) for C 41	
Mechanical seal	Carbon - Ceramic - NBR	

Special features on request

- Other voltages.
- Frequency 60 Hz (as per 60 Hz data sheet).
- Protection IP 55.
- Special mechanical seal
- Higher or lower liquid or ambient temperatures.
- Motor suitable operation with frequency converter.

Coverage chart n ≈ 2900 rpm

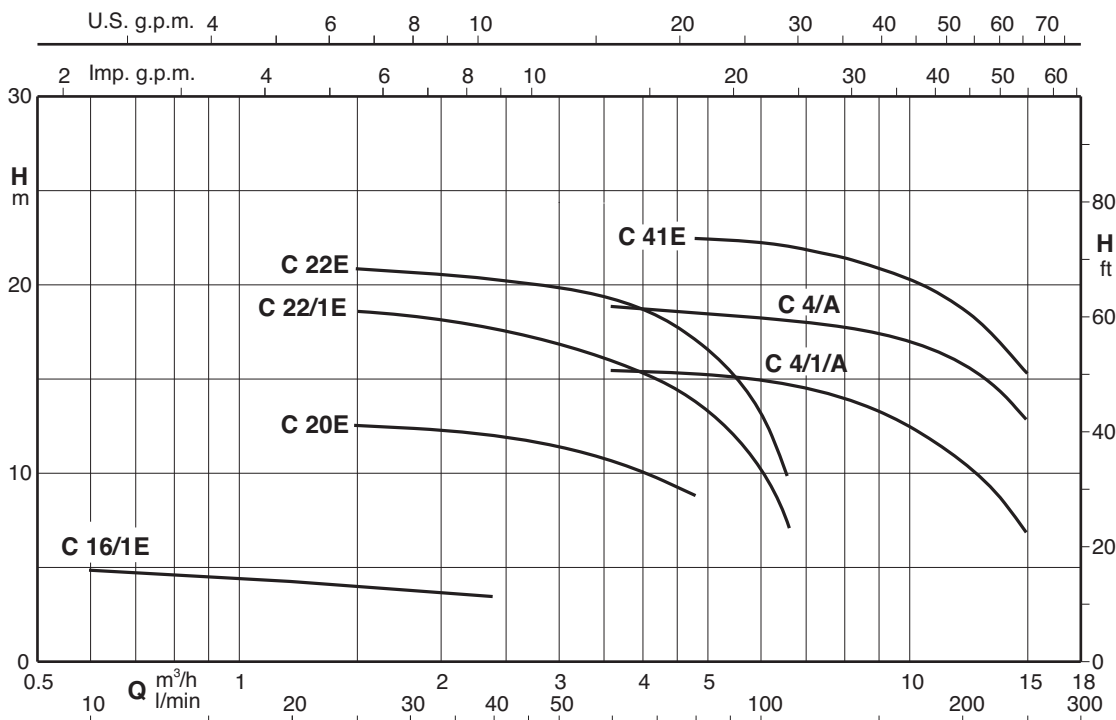



Performance $n \approx 2900$ rpm

3 ~	230V 400V		1 ~	230V		P ₁		P ₂		Q m ³ /h l/min																	
	A	A		A	kW	kW	HP	H m	0,6		0,9	1,2	1,5	1,8	2,4	3	3,6	4,8	6	6,6	8,4	9,6	10,8	12	13,2	15	
C 16/1E B-C 16/1E	1,7	1	CM 16/1E B-CM 16/1E	1,2	0,16	0,15	0,2			5	4,7	4,4	4,2	4	3,6												
C 20E B-C 20/A	1,9 2,3	1,1 1,3	CM 20E B-CM 20/A	2,5 2,8	0,4	0,37	0,5						12,3	12,2	12	11,5	10,8	9									
C 22/1E B-C 22/1/A	2,4 2,3	1,4 1,3	CM 22/1E B-CM 22/1/A	3 3,6	0,8	0,45	0,6						18	18	17,5	17	16	14	10	7,5							
C 22E B-C 22/A	3	1,7	CM 22E B-CM 22/A	3,5 4,5	0,9	0,55	0,75						20,5	20	20	19	18,5	16,5	14	12							
C 4/1/A	3	1,7	CM 4/1/A	4,5	0,91	0,55	0,75										15,6	15,4	15,2	15	14	13,1	12	10,8	9,5	7	
C 4/A B-C 4/1/E	3,7 3,3	2,2 1,9	CM 4/A B-CM 4/1/E	5,7 5,8	1,2	0,75	1										19	18,8	18,5	18,3	17,7	17,4	16,8	16	15	13	
C 41E B-C 41E	4,7	2,7	CM 41E B-CM 41E	7,4	1,6	1,1	1,5											22,4	22,3	22,2	21,5	21	20,5	19,5	18	15,5	

P₁ Maximum power input. P₂ Rated motor power output. B-C, B-CM = Bronze construction. H Total head in m. ρ = Density 1000 kg/m³. ν = Kinematic viscosity max 20 mm²/sec. Tolerances according to ISO 9906, annex A.

Dimensions and weights

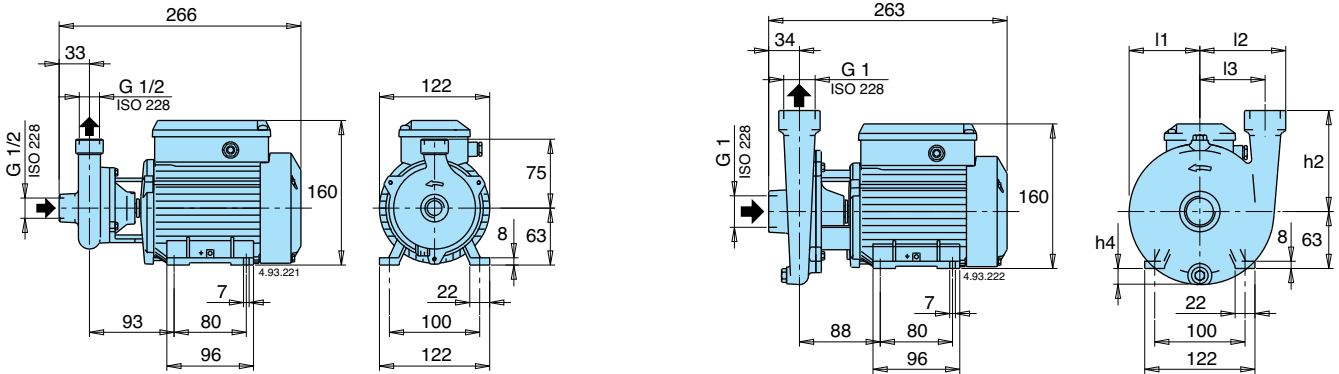

TYPE	kg
C 16/1E	5,2
CM 16/1E	5,2

TYPE	kg
B-C 16/1E	5,6
B-CM 16/1E	5,6

TYPE	mm					kg	
	h2	h4	l1	l2	l3	C	CM
C 20E	90	5	67	82	60	6,8	6,8
C 22/1E - C 22E	110	17	77	94	71	8 - 8,3	8 - 8,3

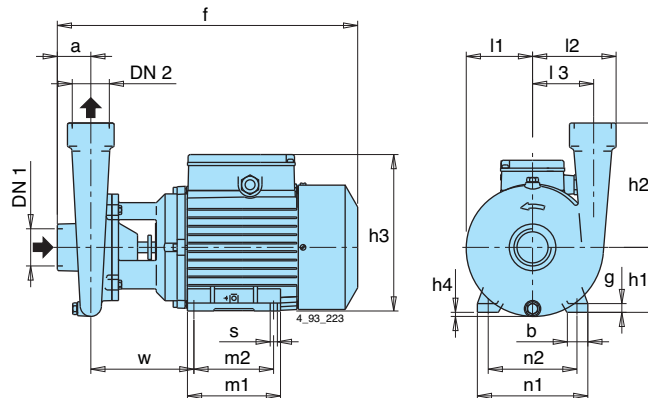

TYPE	DN ₁ ISO 228	DN ₂	mm																	kg			
			a	f	h1	h2	h3	h4	m1	m2	n1	n2	b	s	l1	l2	l3	w	g	C	CM	B-C	B-CM
- B-C 20/A	G 1	G 1	35	303	71	90	182	-	106	90	134	112	22	7	70	84	60	105	10	-	-	9,1	9,1
- B-C 22/1/A - B-C 22/A	G 1	G 1	35	303	71	110	182	9	106	90	134	112	22	7	81	93	71	106	10	-	-	9,3 9,6	10,3 10,6
C 4/1/A - C 4/A	- G 1 1/2	G 1 1/2	43	304	71	160	182	18	106	90	134	112	22	7	85	108	78	100	10	10,8 11,8	11,8 12,8	- -	- -
- B-C 41/E C 41E - B-C 41E	G 1 1/2	G 1 1/2	43	380	80	160	208	9	125	100	155	125	30	9,5	85	108	78	132	10	- 18,5	- 19,3	16,3 19,2	17,9 20,1



Characteristic curves $n \approx 2900$ rpm

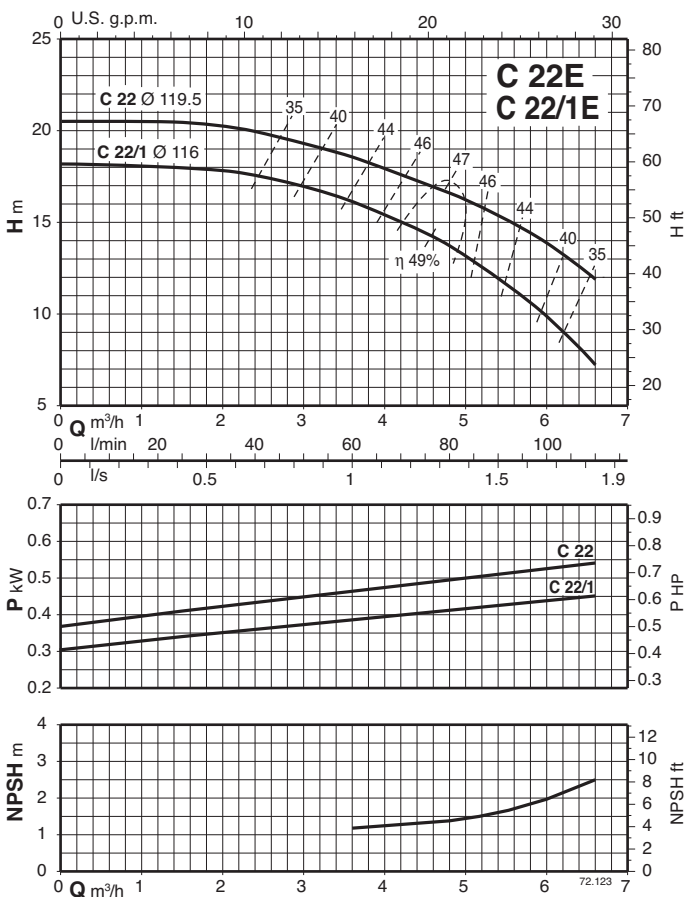
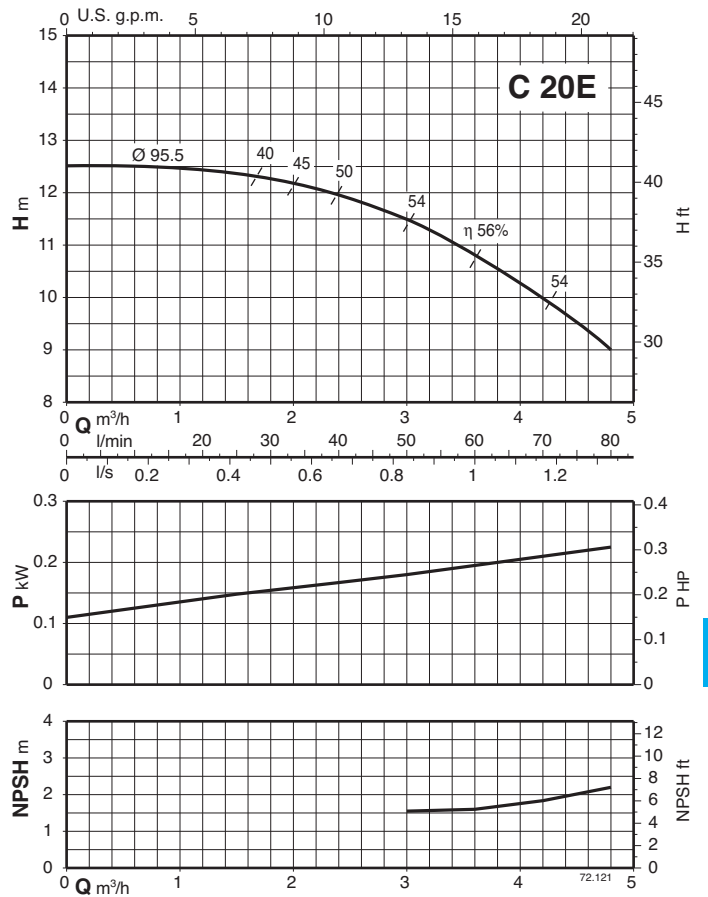
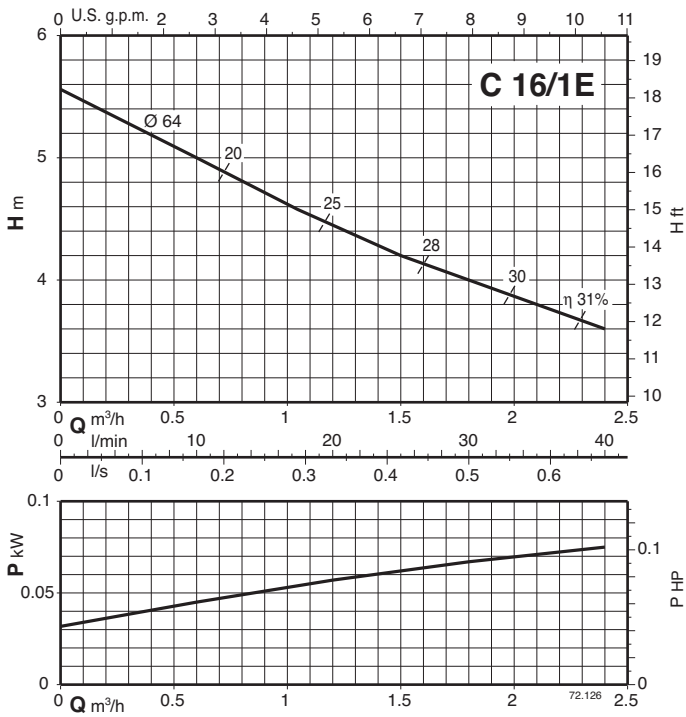

Characteristic curves $n \approx 2900$ rpm

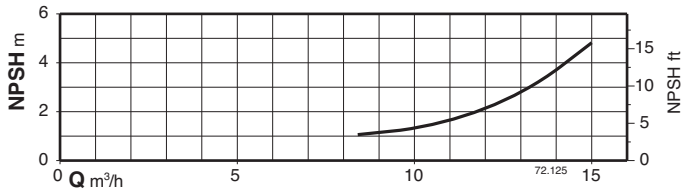
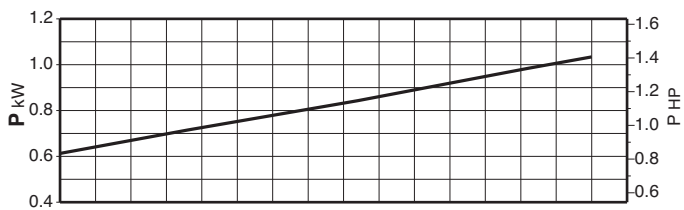
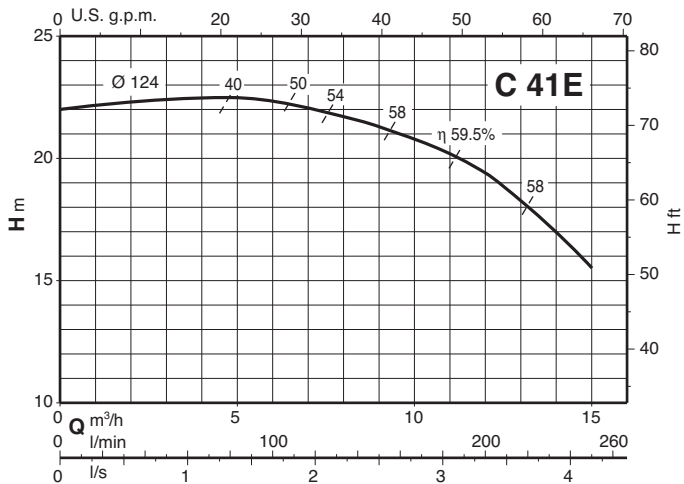
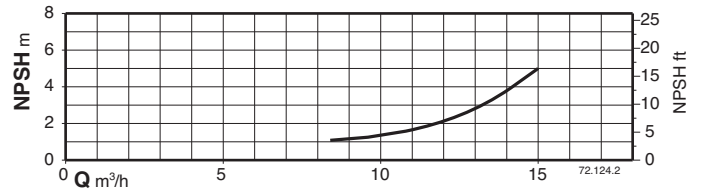
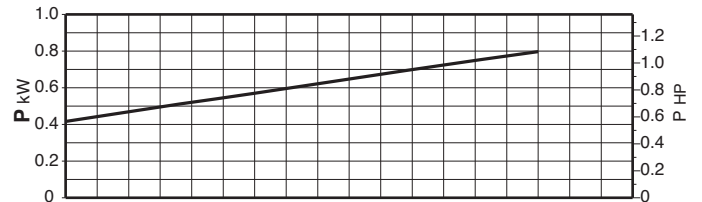
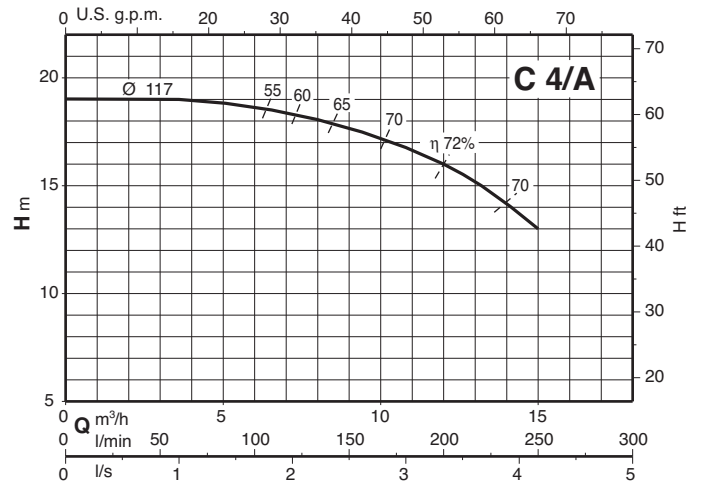
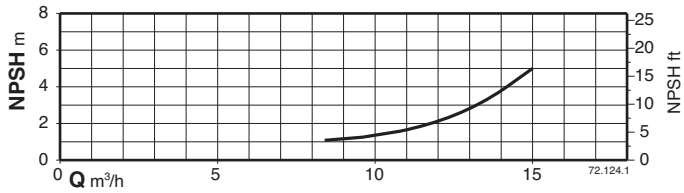
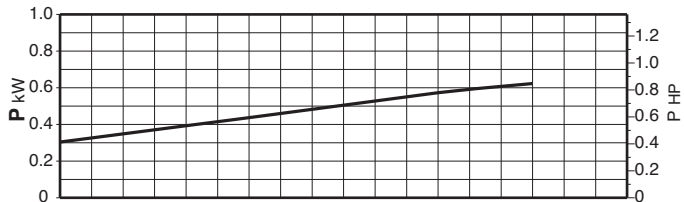
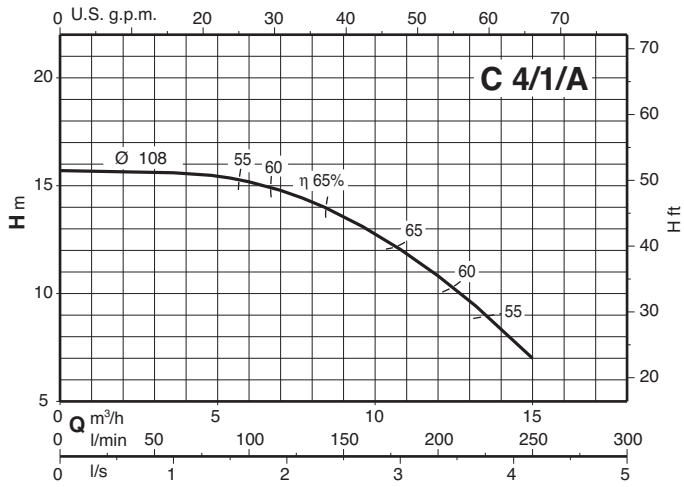



Features

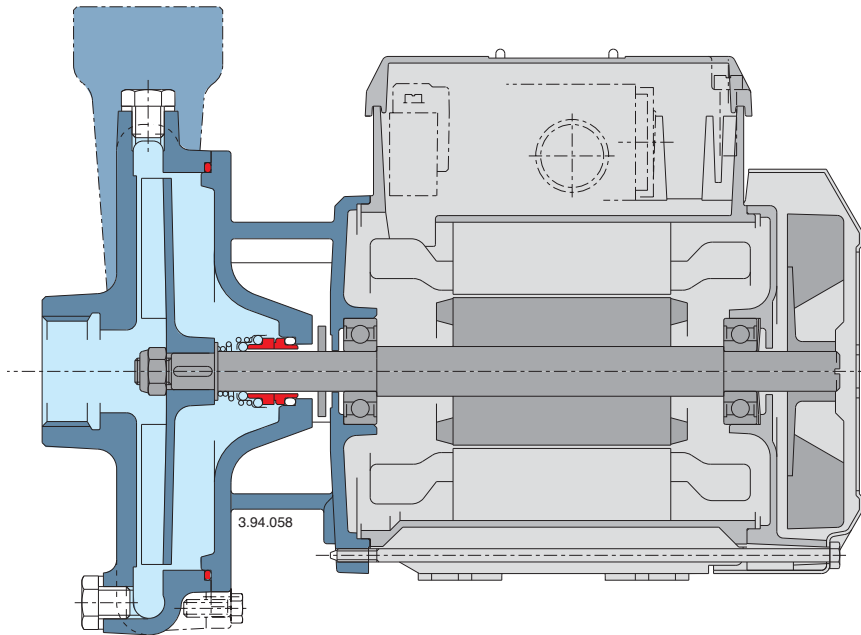

FLEXIBILITY

The option to choose between cast iron and bronze materials for the hydraulic parts in contact with the pumped liquid allows C series pumps to be selected for use with different types of liquids.

SOLID PARTS

The open impeller allows for the passage of suspended solids in pumped liquid.

RELIABILITY

The bearing and shaft are designed to ensure the reduction of the stress, providing high reliability under all operating conditions.