

CHARACTERISTICS

USES - Two impellers compact centrifugal pumps for constructing pressurisation systems irrigation systems, for civil and industrial plant: guarantee good ratio between pressure and delivery.

CONSTRUCTION FEATURES - Cast iron pump casing with threaded openings; cast iron motor bracket; impeller in Noryl® or in brass; ceramic - graphite mechanical seal; motor shaft in AISI 303 steel on the hydraulic side; world leading brand ball bearings; liquid temperature range 0 - 90°C (0 - 50°C if impeller in Noryl®); max. operating pressure 8 bar.

MOTOR - 2 pole electric induction motor for continuous operations; stator made with low-loss laminated electric sheet steel; insulation Class F; IP 44 protection level; thermal protection for single-phase models; the user is responsible for supplying protection for the three-phase models.

ON REQUEST - Other operating voltages and frequencies; special mechanical seal; special liquids.

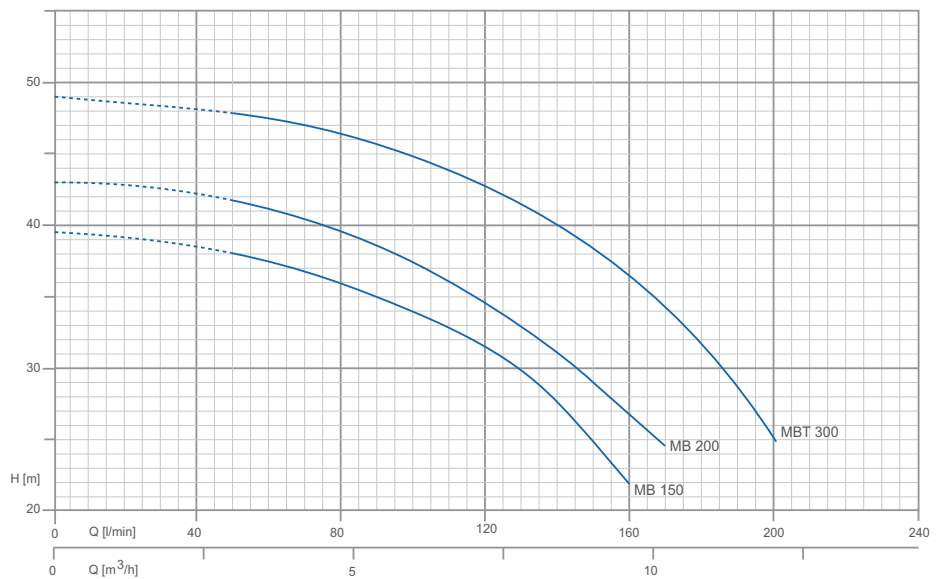

Dimensions

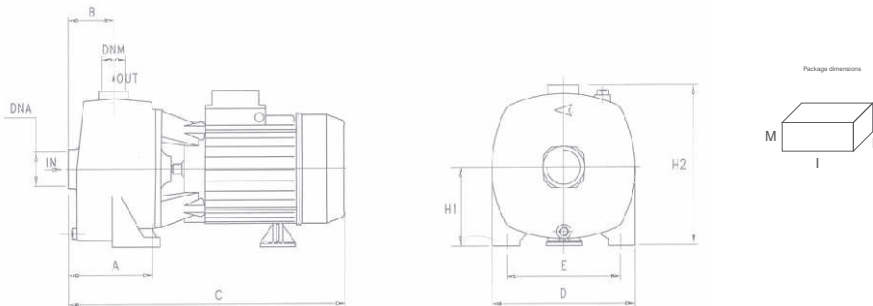

Technical data

TYPE		P2P1		(kW)				AMPERE							
1~	3~	(HP)	(kW)	1~3~		1x230V 50Hz	3x400V 50Hz	0	2.4	4.8	7.2	9.6	12		
230 V - 50 Hz	230 / 400 V - 50 Hz			1~3~										0	40
MB 150	MBT 150	1.5	1.1	1.60	1.55	7.7	2.9	39.5	38.5	36	30.8	22	-		
MB 200	MBT 200	2.2	1.65	2	1.90	9.5	3.6	43	42.1	39.5	34.5	26	-		
MB 300	MBT 300	3	2.2	-	2.60	-	4.8	49	48.4	47.2	43.6	36.5	25		

TYPE	DIMENSIONS (mm)											Kg	
	A	B	C	D	E	H1	H2	DNA	DNM	I	L		M
MB 150	108	73	385	205	165	115	242	1"1/2G	1"1/4G	405	225	295	21.2
MB 200	108	73	385	205	165	115	242	1"1/2G	1"1/4G	405	225	295	21.7
MB 300	108	73	385	205	165	115	242	1"1/2G	1"1/4G	405	225	295	21.7